



Fast Season S 230V 1N 50hz

Seasoner Cabinet / Armadio Stagionatore

CAPACITY / CAPACITÀ

-10°C / +35°C

Working Temperature / Temperatura di esercizio

| | | | |
|-----------------|-----------|-----------------------------|-----------|
| TRAYS TEGLIE | 26 | TRAYS PITCH PASSO TEGLIE | 50 |
| 600 x 400 (mm) | | (mm) | |

FEATURES

Tecnomac presents Fast Season S, a maturing cabinet dedicated to the maturing of cheeses and the preservation of products. Tecnomac experience is enclosed in an user-friendly 7" Touch control panel, that implements new set up options and solutions. More languages are available on the display.

- Touch control panel 7"
- Capacitive display
- Fans speed adjustment
- Electronically controlled humidifier
- High energy saving
- USB Drive, HACCP data download
- Ethernet-MODBUS RJ45 connection
- 70 mm panels thickness
- Storable recipes
- Low energy consumption fans
- Multiple Languages (IT-EN-FR-ES-DE-DK-CZ-FIN)

CARATTERISTICHE

Tecnomac presenta Fast Season S, un armadio stagionatore dedicato alla stagionatura dei formaggi e alla conservazione dei prodotti. L'esperienza di Tecnomac nel settore è racchiusa in un pannello di controllo 7" touch, semplice da utilizzare, che implementa nuove soluzioni di regolazione.

- Pannello di controllo Touch 7"
- Display capacitivo
- Ventilatori a velocità regolabile
- Umidificatore a controllo elettronico proporzionale
- Alto risparmio energetico
- Porta USB, scarico dati HACCP
- Connessione Ethernet-MODBUS RJ45
- Spessore isolamento 70mm
- Ricette memorizzabili
- Ventilatori a basso consumo energetico
- Multilingua (IT-EN-FR-ES-DE-DK-CZ-FIN)

OPTIONAL / OPTIONAL

- | | |
|---------------------------|--------------------|
| • Sanitizzazione ad Ozono | • Ozone sanitation |
| • Versioni a 60 Hz | • 60 Hz versions |

CONTROL & IOT / CONTROLLO & IOT

| | |
|--------------------------------------|----------------------------------|
| Display Full touch capacitivo da 7 " | Capacitive Full touch 7 "display |
| / Industry 4.0 ready | / Industry 4.0 ready |

FEATURES / CARATTERISTICHE

| | |
|--|------------------------------|
| Power supply / Alimentazione Elettrica | 230V/1N/50HZ |
| Code number / Codice Prodotto | Fast season S |
| Dimensions / Dimensioni (LxPxA) (WxDxH) | 730 x 820 x 2130-2185 mm |
| Trays capacity / Capacità Teglie 600x400 mm | 26 |
| Compressor / Compressore | Hermetic |
| Gas charge - Type / Carica gas - Tipo | R290 (GWP 3) |
| Refrigeration power / Potenza refrigerante (-10°C/+45°C) | 513 W |
| Electric Power - Current Max / Max Potenza - Corrente | 1750 W - 9,5A |
| Heating Power / Potenza riscaldante | 600 W |
| Net - gross Weight / Peso netto - lordo | 148 / 169 kg |
| Shipment data / Dati spedizione (WxDxH - kg) | 810 x 925 x 2275 mm - 169 kg |
| Defrost / Sbrinamento | Automatic |
| Minima conducibilità acqua / Minimum water conductivity | 250 µS |

Fast Season S 230V 1N 50hz

Seasoner Cabinet / Armadio Stagionatore

DIMENSIONS / DIMENSIONI

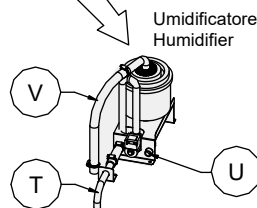
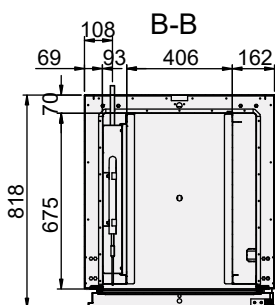
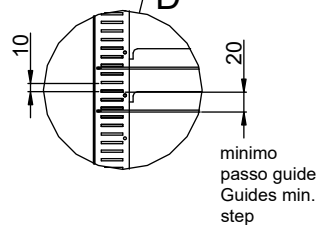
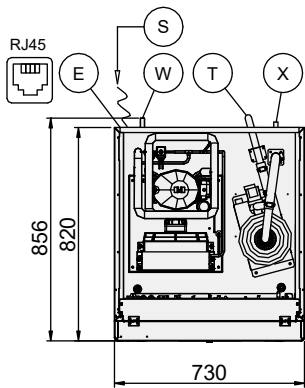
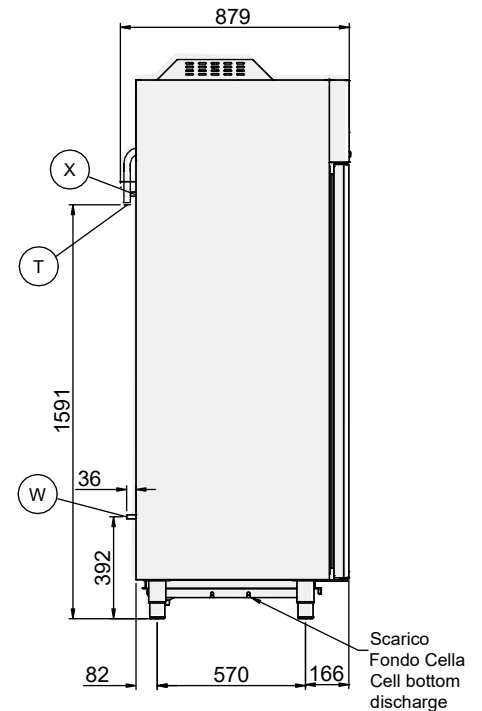
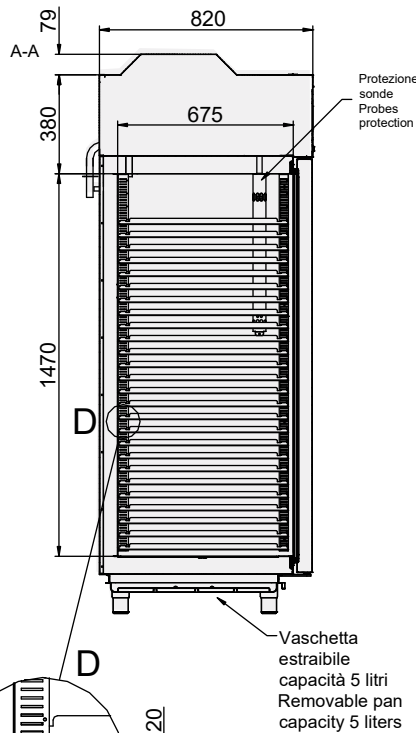
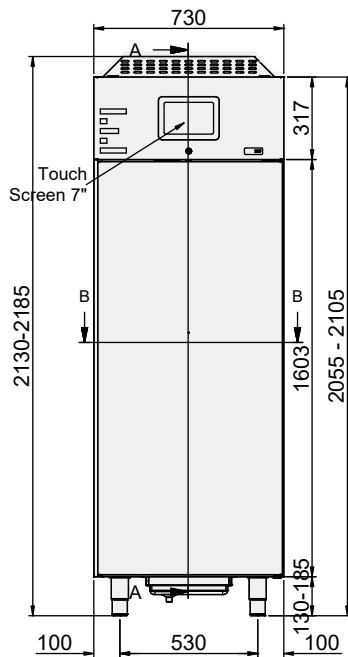

! Minima conducibilità acqua
Minimum water conductivity
250 μ S / cm

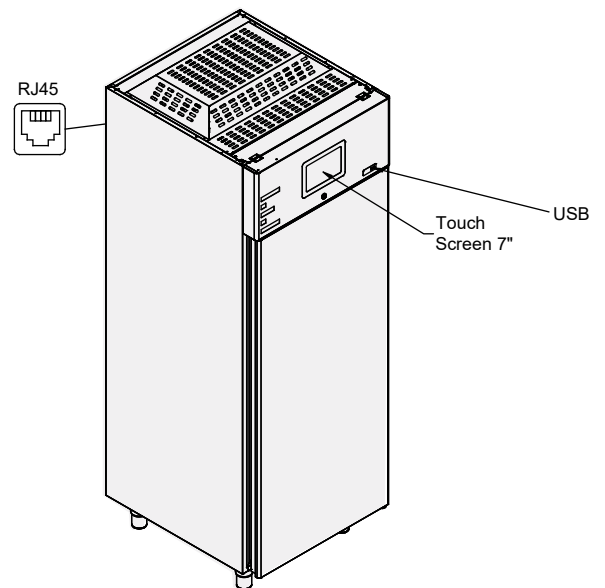

S Cavo alimentazione elettrica
Electrical cable supply
Schuko plug
Spina schuko
3 x 1.5 L= 2000 mm

U Ingresso acqua umidificatore
Humidifier water inlet
diam 3/4 "

W Scarico condensa evaporatore
Water evap. discharge

T Scarico acqua Umidificatore
Humidifier water discharge
diam 32 mm

X Scarico condensa int.
Internal Water discharge

E Uscita Ethernet-MODBUS
Ethernet-MODBUS
output

V Uscita vapore
Steam Line

our technology,
your taste

Tutti i modelli / All models:
Fast season S

Fast Season S 230V 1N 50hz

Seasoner Cabinet / Armadio Stagionatore

CONTROL PANEL / PANNELLO DI CONTROLLO



Manual retarder proving cycle
Ciclo fermalievitazione manuale



Fermabiga cycle
Ciclo fermabiga



Retarder proving multiphase
Programma fermalievitazione Multifase

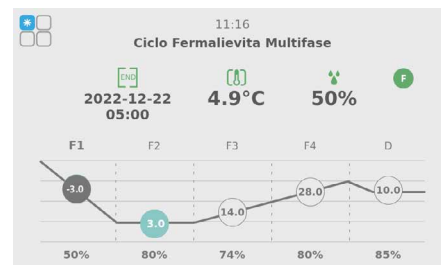

Additional functions
Funzioni aggiuntive



Retarder proving multiphase Set
Set Programma fermalievitazione Multifase



Screen lock
Blocca schermo

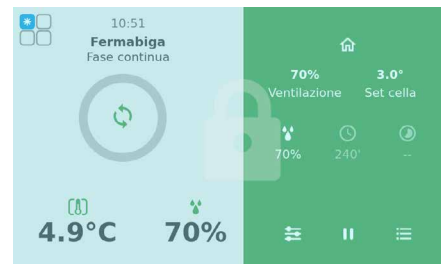

Seasoner Recipe collection
Raccolta ricette stagionatore

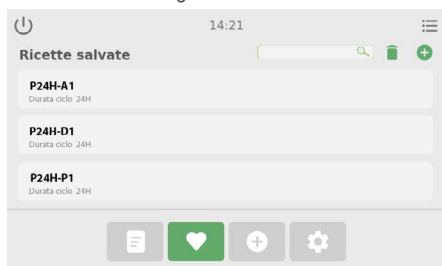

Alarm list
Riepilogo Allarmi



Multiple Languages
Multi lingua

