



PLev S

230V 1N 50hz

Retarder Prover Cabinet / Armadio Fermalievita

CAPACITY / CAPACITÀ

-10°C / +35°C

Working Temperature / Temperatura di esercizio

TRAYS TEGLIE	26	TRAYS PITCH PASSO TEGLIE	50
600 x 400 (mm)		(mm)	

FEATURES

Tecnomac introduces Planner Lev S, a retarder prover cabinet dedicated to products proving and conservation.

Tecnomac experience is enclosed in an user-friendly 7"

Touch control panel, that implements new set up options and solutions.

More languages are available on the display.

- Touch control panel 7"
- Capacitive display
- Fans speed adjustment
- Fermabiga program
- Electronically controlled humidifier
- High energy saving
- USB Drive, HACCP data download
- Ethernet-MODBUS RJ45 connection
- 70 mm panels thickness
- Storable recipes
- Low energy consumption fans
- Multiple Languages (IT-EN-FR-ES-DE-DK-CZ-FIN)

CARATTERISTICHE

Tecnomac introduce Planner Lev S, un armadio fermalievitazione dedicato alla lievitazione e conservazione dei prodotti.

L'esperienza di Tecnomac nel settore è racchiusa in un pannello di controllo 7" touch, semplice da utilizzare, che implementa nuove soluzioni di regolazione.

- Pannello di controllo Touch 7"
- Display capacitivo
- Ventilatori a velocità regolabile
- Programma Fermabiga
- Umidificatore a controllo elettronico proporzionale
- Alto risparmio energetico
- Porta USB, scarico dati HACCP
- Connessione Ethernet-MODBUS RJ45
- Spessore isolamento 70mm
- Ricette memorizzabili
- Ventilatori a basso consumo energetico
- Multilingua (IT-EN-FR-ES-DE-DK-CZ-FIN)

OPTIONAL / OPTIONAL

- Sanitizzazione ad Ozono
- Ozone sanitation
- Versioni a 60 Hz
- 60 Hz versions

CONTROL & IOT / CONTROLLO & IOT

Display Full touch capacitivo da 7" / Industry 4.0 ready

Capacitive Full touch 7" display / Industry 4.0 ready

FEATURES / CARATTERISTICHE

Power supply / Alimentazione Elettrica	230V/1N/50HZ
Code number / Codice Prodotto	Planner Lev S
Dimensions / Dimensioni (LxPxA) (WxDxH)	730 x 820 x 2130-2185 mm
Trays capacity / Capacità Teglie 600x400 mm	26
Compressor / Compressore	Hermetic
Gas charge - Type / Carica gas - Tipo	R452A (GWP2141)
Refrigeration power / Potenza refrigerante (-10°C/+45°C)	483 W
Electric Power - Current Max / Max Potenza - Corrente	2200 W - 10A
Heating Power / Potenza riscaldante	600 W
Net - gross Weight / Peso netto - lordo	148 / 169 kg
Shipment data / Dati spedizione (WxDxH - kg)	810 x 925 x 2275 mm - 169 kg
Defrost / Sbrinamento	Automatic

DIMENSIONS / DIMENSIONI

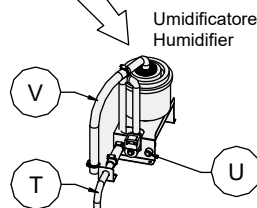
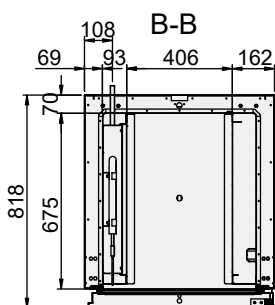
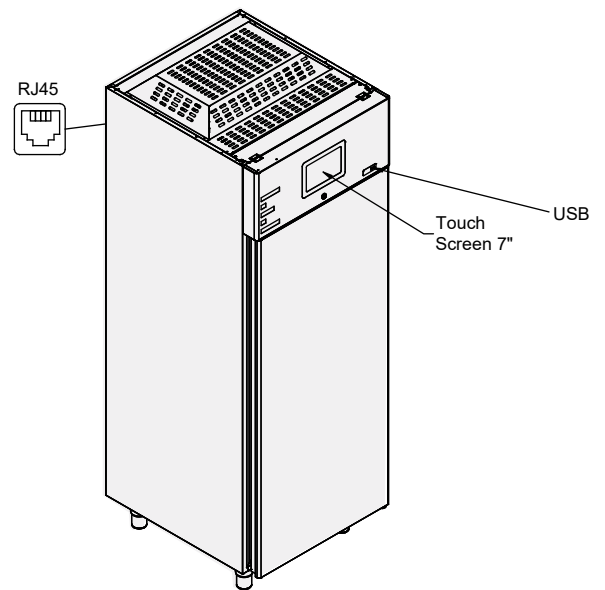
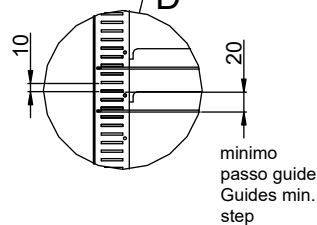
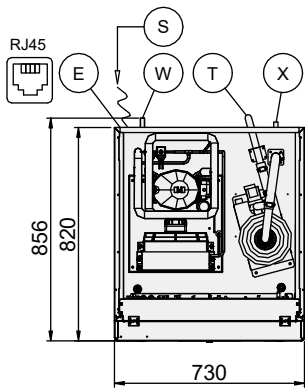
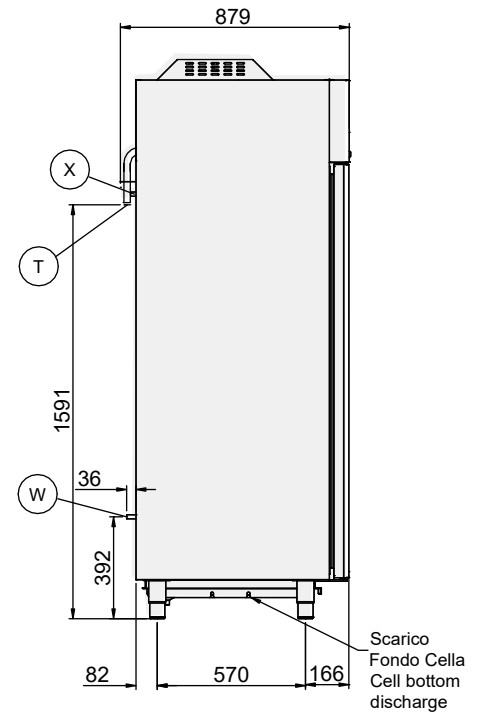
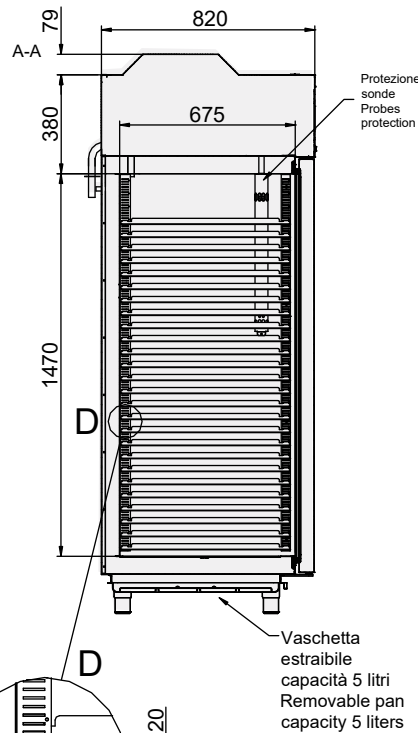
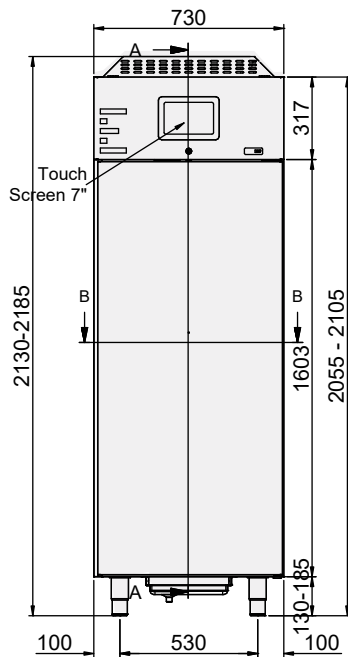

S Cavo alimentazione elettrica
Electrical cable supply

Schuko plug
Spina schuko
3 x 1.5 L= 2000 mm

U Ingresso acqua umidificatore
Humidifier water inlet
diam 3/4 "

T Scarico acqua Umidificatore
Humidifier water discharge
diam 32 mm

E Uscita
Ethernet-MODBUS
Ethernet-MODBUS
output

W Scarico condensa evaporatore
Water evap. discharge

X Scarico condensa int.
Internal Water discharge

V Uscita vapore
Steam Line

CONTROL PANEL / PANNELLO DI CONTROLLO



Manual retarder proving cycle
Ciclo fermalievitazione manuale



Fermabiga cycle
Ciclo fermabiga

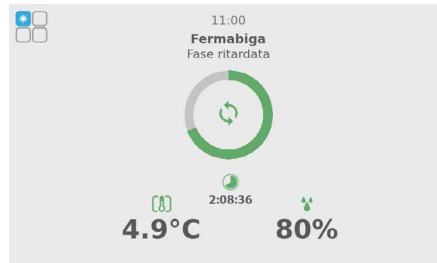

Retarder proving multiphase
Programma fermalievitazione Multifase

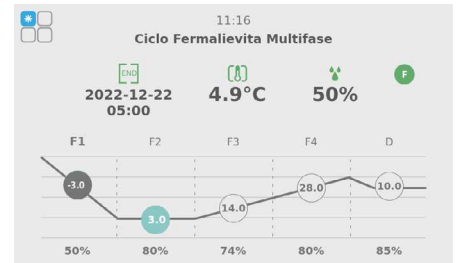

Additional functions
Funzioni aggiuntive



Retarder proving multiphase Set
Set Programma fermalievitazione Multifase



Screen lock
Blocca schermo

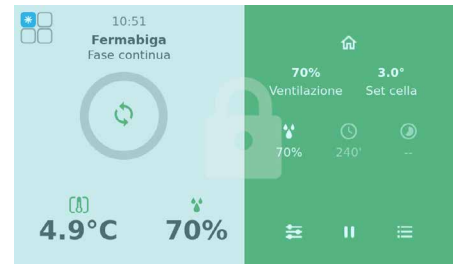

Recipe collection
Raccolta ricette

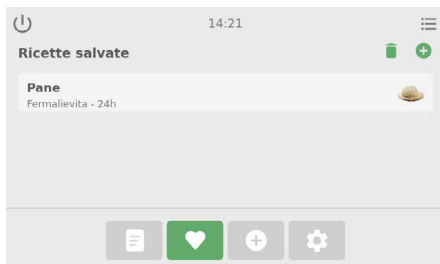

Alarm list
Riepilogo Allarmi



Multiple Languages
Multi lingua

